

Solar Charge Controller

PWM 12/24V 10A/20A

User Manual

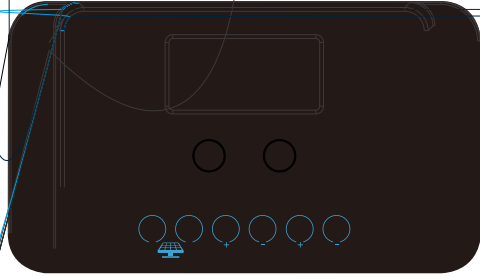

Thanks for your purchase of our solar charge controller!

This device is a PWM 24V 10A/20A charge controller ideal for many applications. It's flush mount design makes it perfect for solar power systems in RV's and boats. Please be sure to read through the following pages and familiarize yourself with the features and settings of the controller.

Description of tools and symbols

Marks & Tools	Item	Description
	High Voltage Danger Mark	High voltage might exist in the controller, and all operations ought to be made by electrical professions.
	Heating Caution	Keep distance with the controller, due to probable heating when it's working.
	EU WEEE Mark	Don't litter the controller as trash.
	Wire Stripper	For wire stripping.
	Multiply Meter	To check the positive/negative connection, and to check current or other electrical value.
	Anti-static Glove	To avoid controller damage caused by static electricity from human body.
	Electrical Tape	To tape the wiring joint for safety reason.
	Screwdriver	To fix the screws.

Controller Features

Thanks for using our product. This PWM solar charge controller is typically a device for solar charge regulation and discharge output control, with LCD screen display and extra 5V USB, mainly used in small size solar DC power system.

- a) Most types of battery can be supported and selected, like AGM (or other sealed type), GEL, Flooded, and Lithium battery (with various voltage settings), by key setting in the controller.
- b) 12V/24V battery system auto recognition for lead-acid type battery or non-lithium type battery.
- c) PWM 3-phases charging: equalize - boost - float (for Flooded, AGM, GEL lead-acid type battery)

- d) LCD screen, displaying system working status and setting parameters.
- e) User-friendly key press operation, simple and easier.
- f) Extra 5V USB output, suitable for mobile DC charge.
- g) Multiply output control mode selection: light control mode, light + time control mode, test & debug mode, manual mode, and always-on mode.
- h) Industrial grade design, for better function under extreme environment conditions.
- i) Full range of electrical protections, like anti-connection in PV and Battery wiring, load short circuit, battery over-discharge, system over voltage, and etc.

Controller Illustration

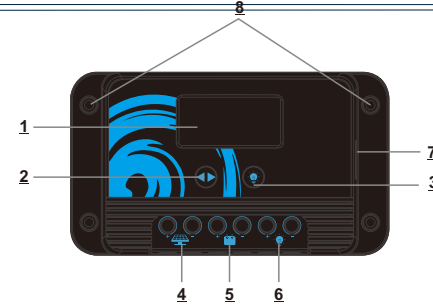

1	LCD Display	5	Load wiring terminal
2	Menu Key	6	Function Key
3	Solar input wiring terminal	7	USB Port
4	Battery wiring terminal	8	Installation holes

Wiring Sequences

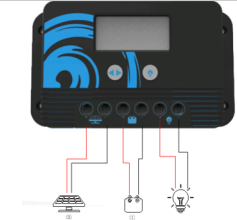

- First: Connect the battery first, please choose cable accordingly.
- Second: Connect the solar panel
- Last: Connect the load wiring to the load (if necessary)

LCD Display Illustration

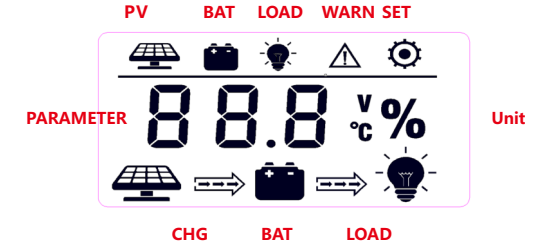

1. Display Section

ITEM	DESCRIPTION	ICON
Status	Current system working status	
Parameter	Parameter value for selected item	
Selected Item	Current selected item	

2. Solar(PV), Battery & Charge Indications

ICON	ITEM	STATUS	INDICATION REMARK
	PV Indication	Steady ON	PV volt higher than light control volt
		OFF	PV volt lower than light control volt
		Slow flash ON	Charging
	Battery Indication	Fast blink ON	PV over voltage
		Steady ON	Battery is OK
		OFF	Battery is abnormal
		Fast blink ON	Battery over discharge
	Charging Indication	Floating	Charging
		No float	No charge

3.Operations

3.Operations

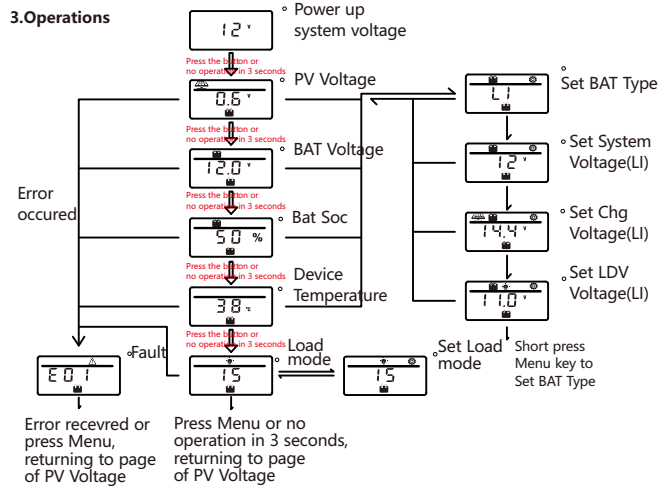

Remarks:
 *The page will enter to the next one if no operation in 3 seconds
 *The system will automatically enter to the "error" page when there is an error detected.
 This page will stay still until the user operates in the controller to enter to the other pages.

Button Setting Info

BUTTON	SETTING STATUS	PRESS	FUNCTION
	In Setting	Long press	Enter page not for settings
		Short press	Enter next page for settings
	Not in Setting	Long press	Enter page for settings
		Short press	Enter next page not for settings
	In Setting	Long press	No function
		Short press	To adjust parameter
	Not in Setting	Long press	No function
		Short press	Load switch (in manual mode)

Remark: "In Setting" means the user is in the page for setting parameters.

Battery Type & Parameter Settings

1. Battery Type Setting

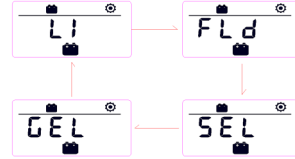

ITEM	BATTERY TYPE	DESCRIPTION
FLD	Flooded battery	Battery system voltage auto recognition; parameters default set.
SEL	Sealed/AGM battery	
GEL	Gel battery	
LI	Lithium battery	System voltage, charge/discharge parameters adjustable

2. System Voltage (For Li battery only)

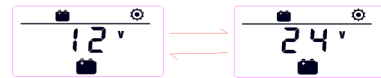

3. Charge Voltage Settings (For Li battery only)



4. Over-discharge Voltage Settings (For Li battery only)



5. Load Mode Settings



MODE NUMBER	DEFINITION	DESCRIPTION
0	Light switch control	The PV voltage turns on the load switch in time of light control delay
1~14	Light + Time control	The PV voltage turns on the load switch and shut it down in time of settings
15	Manual switch	Turns on/off the load by press the load button
16	Testing switch	Turns on the load immediately with no delay and then turns off
17	Always on	The load keeps on until battery low voltage disconnect

Controller Error List & Recovery

CODE	DRROR	ANALYSIS	RECOVER SOLUTION
E00	No error	--	--
E01	Over-discharged	The battery voltage has been discharged to a low level, load cuts off	Recover once the battery voltage return to the normal level. Load is allowed to turn on then.
E02	Battery over voltage	The battery voltage has exceeded the max level.	Recover once the battery voltage return to normal level.
E04	Load short circuit	The load gets short circuited	Check the wiring and loading condition.
E05	Load over loaded	The load power has exceeded the rated value	Check and decrease the load power requirement.
E06	Device over heating	The controller gets too hot in high temperature, the charge cuts off	Get the device cooler to decrease the temperature
E08	Charge power over rated	The input power has exceeded the max rated value	To decrease the input power
E10	PV over voltage	The PV input voltage is too high	To decrease the input voltage
E13	PV anti-connection	The PV side has anti-connection	Check and re-connect the PV wires in right position
E14	Battery anti-connection	The battery side has anti-connection	Check and re-connect the Battery wires in right position

Controller Specifications

* Remark "n" : when system voltage is 12V, n=1; when system voltage is 24V, n=2

ITEM	PARAMETERS			
	AP2410	AP2420		
Model No.	AP2410	AP2420		
System Voltage	12V/24VAuto(FLD/GEL/SLD), 12V/24V(manual set for Li)			
No-load Loss	8ma(12V), 12ma (24V)			
Max PV Input Voltage	< 55V			
Rated Charge Current	10A	20A		
Max PV Input Power	170W/12V; 340W/24V	340W/12V; 680W/24V		
Battery Type Selection	FLD	SEL	GEL	LI
Equalize Charge Voltage	14.8V*n	14.6V*n	--	--
Boost Charge Voltage	14.6V*n	14.4V*n	14.2V*n	14.4V*n (adjustable)
Float Charge Voltage	13.8V*n			--
Boost Charge Recovery Volt	13.2V*n			--
Over Discharge Recovery Voltage	12.6V*n			12.6V*n (auto adjust to 12V or 24V system voltage)
Over Discharge Voltage	11.1V*n			11.1V*n (adjustable)
Light Control Voltage	5V (12Vsystem) , 10V(24Vsystem)			
Light Control Delay Time	10s			
Load Modes	light control(dusk-to-dawn), light + time control, debug mode, manual control, steady-on mode.			
Operation Temperature	-25°C ~ +65°C			
IP Protection	IP30			
Net Weight	180g	200g		
Communication	NA			
Display	LCD			
Operation Altitude	≤ 3000M			
Controller Size	122*70*34.5mm			

Product Dimension

